



INNOVATION

SBM-L G1S2

GRINDING, DEBURRING AND
EDGE ROUNDING OF PUNCHED, LASER
AND HIGH DEFINITION PLASMA CUT
PARTS IN ONE SINGLE PASS



LISSMAC
METAL PROCESSING

TECHNICAL DATA	SBM-L 1000 G1S2	SBM-L 1500 G1S2
material feed	automatic	automatic
working width	1000 mm	1500 mm
material thickness max.	50 mm	50 mm
G-grinding unit		
main drive motor	2 x 2.2 kW	2 x 3.0 kW
voltage	400 V / 50 Hz	400 V / 50 Hz
S-deburring unit		
main drive motor	4 x 3.0 kW	4 x 3.0 kW
voltage	400 V / 50 Hz	400 V / 50 Hz
total power main drive motors	39 A	41 A
total current consumption of main motor	16.8 kW	18.4 kW
insulation class	IP 54	IP 54
infinitely variable feed speed	0-4 m/min	0-4 m/min
adjustment of material thickness	electric	electric
adjustment of grinding medium	electric	electric
total weight	2460 kg	2785 kg
dimensions (W/D/H in mm)	2754/1480/1748	3254/1480/1748

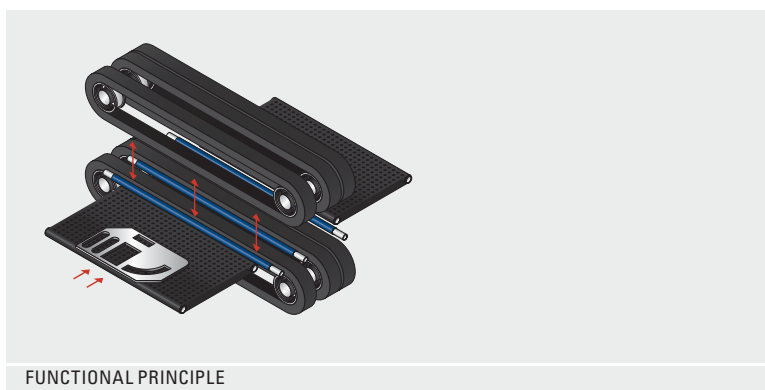
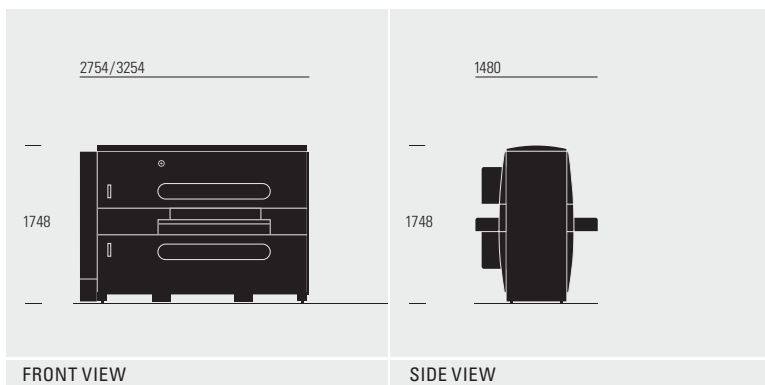

→ Subject to technical change without notice



Lissmac innovative systems for metal processing set high standards for metal finishing. Their unique method of simultaneously grinding, deburring, and edge rounding on inside and outside contours of punched, laser and high definition plasma cut parts on both sides in one single pass is highly efficient.

Features and Benefits –

Grinding and deburring machine SBM-L G1S2

- Deburring and edge rounding of parts up to 50 mm material thickness
- Removal of spots on the sheet metal surface
- Processing both sides of the parts simultaneously eliminates the need of turning heavy parts and processing them for a second time
- Consistent edges on all outside and inside contours
- Dry operation – no hazardous grinding residues or complex drying systems
- Optimum utilization of the abrasive media which moves perpendicular to the feed direction
- Easy operation and maintenance
- Modular design, compact and sturdy construction
- Each tool unit can be individually electrically operated and adjusted
- Each tool unit can be configured according to your specific application
- Easy operation due to the central control panel
- Hydraulic belt tension – fast tool change
- Tool wear display
- The operation of all Lissmac grinding, deburring, and edge rounding machines can be linked and sequenced together with innovative conveyor systems and combined single controls

Advantages compared to manual processing

- Significantly higher productivity combined with superior quality
- Consistent part quality
- Improved and safer work environment for your employees
- No flying sparks, dust, dirt or excessive noise due to automated process

→ OPTIONALLY AVAILABLE:

- DUST COLLECTION SYSTEMS
- CONVEYOR SYSTEMS
- MATERIAL HANDLING
- ROBOTICS, AUTOMATION
- ABRASIVE MEDIA